

## PITCHING INSTRUCTIONS

### Your tent includes:

- 16 x pegs
- 4 x ropes
- 1 x GOLD aluminium pole (1570mm x 9.5mm)
- 1 x BLACK aluminium pole (3020mm x 9.5mm)

1. Select a dry, level site and clear the ground of any sharp objects. Remove the tent from its carry bag, untie fabric ties and unroll the tent. Save the fabric ties to make packing away the tent easier.

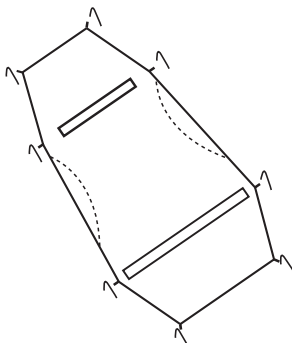

2. Spread out the floor of the inner tent and peg out the eight main pegging points first, ensuring that the tent is pulled taut and secure.

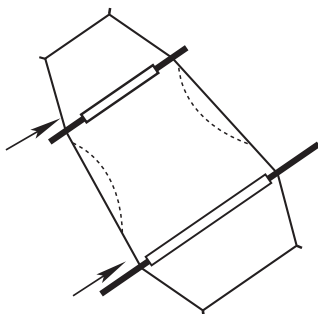

*To make sure the tent stays in place, insert the pegs into the ground at a 45° angle.*

*Pitch the tent so it is in line with the wind, never side on.*

3. Assemble both aluminium poles by interlocking all sections. Insert the GOLD pole through the black sleeve on the inner at the narrowest end and place the pole ends onto the pins (on the ring) at the base of the inner. Repeat with the BLACK pole through the larger sleeve. Attach the speed hooks to the corresponding poles. The inner tent is now pitched.

*Use caution when inserting poles so not to damage sleeves.*

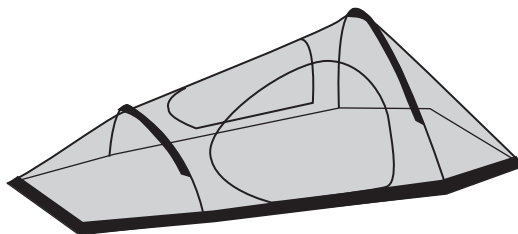

4. Carefully pull the fly over the inner tent. On the underside of the fly attach the Velcro ties to the corresponding poles. This will align the fly and helps in windy conditions. Once aligned, use the black side release clips to secure and adjust the fly.

*The black fly window should be at the narrow end of the tent.*

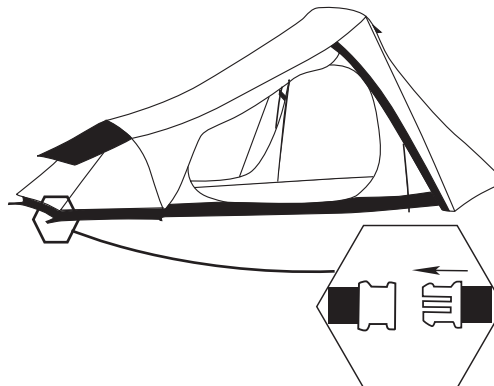

5. Finally, peg out all guy ropes and fine tune the fly so it remains taut and positioned correctly over the tent for ultimate stability.

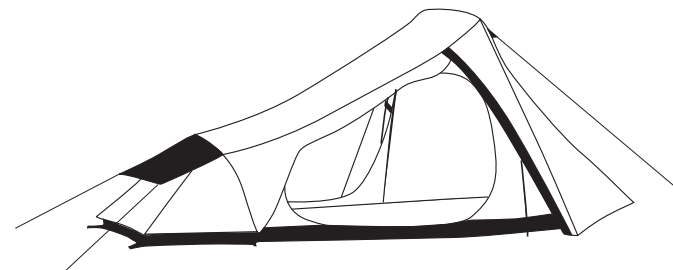

## REVERSE THE PROCEDURE TO LOWER THE TENT

### PACKING INSTRUCTIONS

Pack the poles and pegs into their bags. Evenly lay out the outer fly inside the tent inner leaving all doors and windows open. Fold the inner tent floor from each side to the centre and in half again. Adjust to the length of the poles. Place the poles onto the floor and roll them inside so that the floor is on the outside. Store and pack the tent in its bag.

## TENT CARE INSTRUCTIONS

PLEASE READ ALL OF THE TENT CARE INFORMATION AND INSTRUCTIONS INCLUDED WITH THIS TENT BEFORE USING YOUR TENT FOR THE FIRST TIME.

1. Before you use your new tent, fully unpack and pitch it at home. It is important to familiarise yourself with the set up procedure and the various features.
2. Select a site that is level, clear of any sharp objects, is dry, will drain well if it rains and is protected from wind and other elements.
3. Keep clear of overhead power lines and trees when setting up your tent.
4. For best and easiest results, enlist the help of at least one other person to assist in pitching the tent.
5. Keep all flame and heat sources away from this tent fabric. Do not use open flame or gas appliances in or near your tent.
6. Do not use aerosol sprays or any solvent based products in or around your tent as these could damage the fabric or special coatings. These products include but are not limited to: repellent spray, hair sprays, alcohol, detergents, fly spray, petrol, kerosene etc.
7. Please note, the warranty on this tent will be deemed void if the product is used for any purpose other than a **temporary, recreational** use shelter.
8. Handle the tent poles carefully. When unfolding and folding the tent poles, do not allow the shock cord to pull and snap the ends together. This can damage the poles ends and result in breakage when the pole is tensioned.
9. Especially in windy conditions, it is essential that you attach guy ropes and fasten them to the ground. We suggest you insert the

pegs into the ground at a 45° angle towards the tent, not straight down. Please note, your tent will not be covered under warranty if wind damage occurs.

10. Use all of the guy ropes and pegs included to ensure your tent is secure and to prevent damage to both yourself and the tent. Check guy ropes/pegs daily.
11. Ensure there is an adequate gap between the fly and inner tent to enable ventilation and to prevent condensation build up.
12. Hold the flaps up, when closing the doors, to take pressure off the zips. Ensure that the tent fabric is never over stretched, especially as this may cause problems with the internal doors.
13. To clean your tent, only ever use a soft sponge and warm water. DO NOT use excess force or other harsh cleaners to remove marks from tent.
14. Ensure the tent is completely dry and clean before storing away and ensure to store it in a dry environment.

### IMPORTANT:

1. Under certain conditions (cold weather, high humidity etc.) condensation may form on the inside of your tent fly. Condensation can occur for many reasons including vapour from your breath, perspiration, cooking nearby or wet clothing inside your tent. This does NOT mean your tent is leaking through the fabric. You can minimise condensation by opening windows and airing out your tent during the day and by removing any wet clothing/towels etc.
2. Try to avoid pitching your tent under trees as tree limbs, falling leaves, sap, bird droppings or excess water dripping from the trees can cause damage to the tent fabric and its special coatings resulting in leakage or discolouration.

3. Only remove the tent pegs by pulling on the peg itself. NEVER pull on the tent or the webbing loops to remove pegs as it could result in damage to the tent or personal injury.
4. DO NOT leave tent pitched for weeks at a time as extended exposure to the sun's ultraviolet rays can damage and/or cause it to discolour. Your tent will not be covered under warranty if you leave it up for many weeks at a time.
5. STORAGE:  
NEVER store your tent wet or dirty (even for short periods of time).  
NEVER store your pegs or poles inside your tent. Always use the separate bags they are supplied in.
6. You may want to insure your tent against loss or damage.

## WARRANTY INFORMATION

The warranty period for this tent is found on the packaging and full details are on the Kiwi Camping website - [www.kiwicamping.co.nz](http://www.kiwicamping.co.nz).

### Key points:

The original purchaser of this product is offered a warranty if during this time period the product fails due to a fault in either materials or workmanship. Service under this warranty is available by returning the product, with your proof of purchase, to where it was purchased. If after inspection it is determined that the product is defective, we will repair or replace it (at our discretion) free of charge. This warranty does not cover misuse, damage caused by accident, storm or wind damage, mildew, neglect, UV degradation and fair wear and tear. Please note, the warranty on this tent will be deemed void if the product is used for any purpose other than a temporary shelter. If the claim is not deemed a warranty or is outside it's warranty period, we can repair the product at a nominal cost.



Distributed by: Aber Living, Hamilton, NZ  
[www.kiwicamping.co.nz](http://www.kiwicamping.co.nz)

5041-09/18